

مؤسسة نور الحسين  
NOOR ALHUSSEIN  
FOUNDATION



**2007**



**-1**

**1-1**

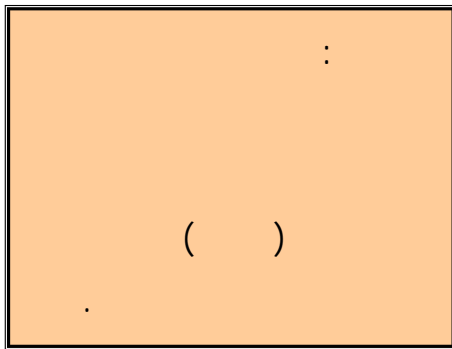

( )

( )

**2-1**

:

|  |  |  |
|--|--|--|
|  |  |  |
|  |  |  |
|  |  |  |
|  |  |  |

- 
- 
- 
- 
- 

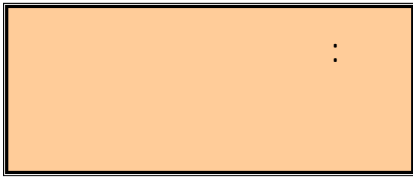

**-2**

**1-2**

:

(P)

(4Ps)





Strength -  
Weaknesses -  
Opportunities -  
Threats -

( )

| <b>(Weaknesses)</b>                                       | <b>(Strengths)</b>  |
|---|---|
| <p>) -</p> <p>( -</p> <p>-</p> <p>-</p> <p>-</p> <p>-</p> | <p>) -</p> <p>( -</p> <p>-</p> <p>-</p> <p>-</p> <p>-</p> |
| <b>(Threats)</b>  | <b>(Opportunities)</b>                                    |
| <p>-</p> <p>-</p> <p>-</p> <p>-</p>                       | <p>-</p> <p>-</p> <p>-</p> <p>-</p>                       |

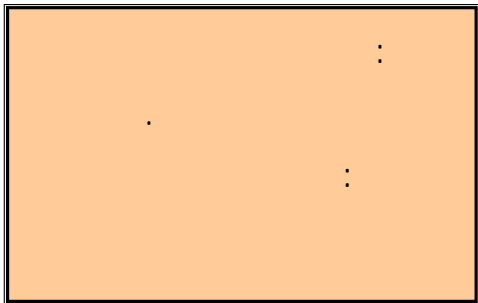

:

■

( )

:

■

:

■

)

(

)

(

(

)

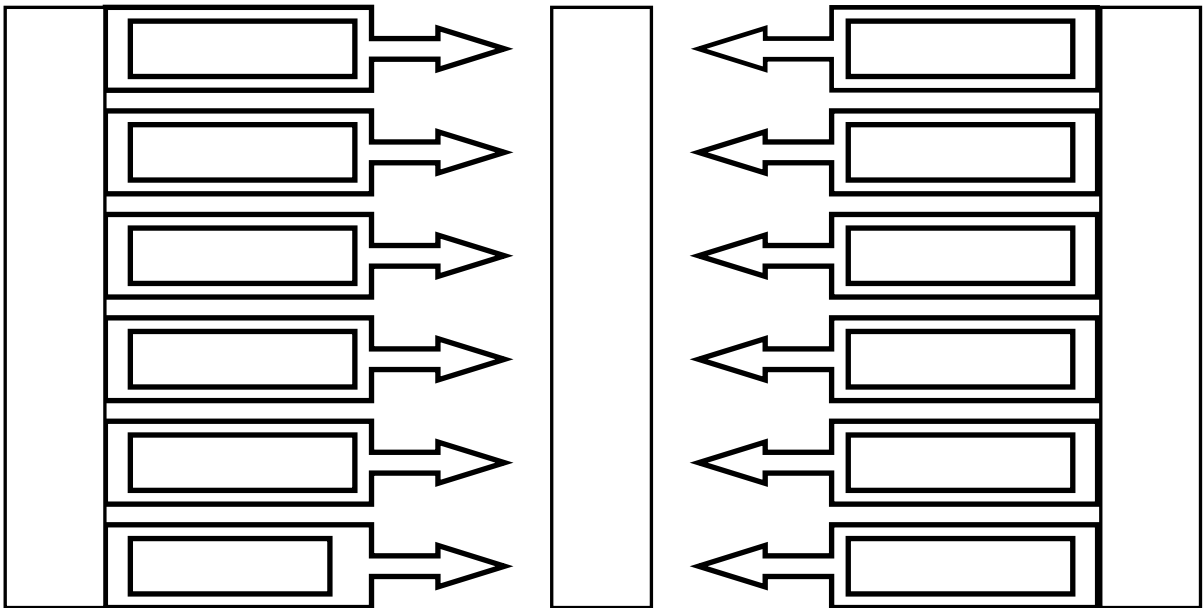

/ (3)

. ( )

(125)

(150)



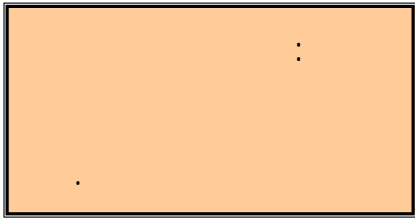

⋮

⋮ ...

- ◆
- ◆
- ◆
- ◆
- ◆

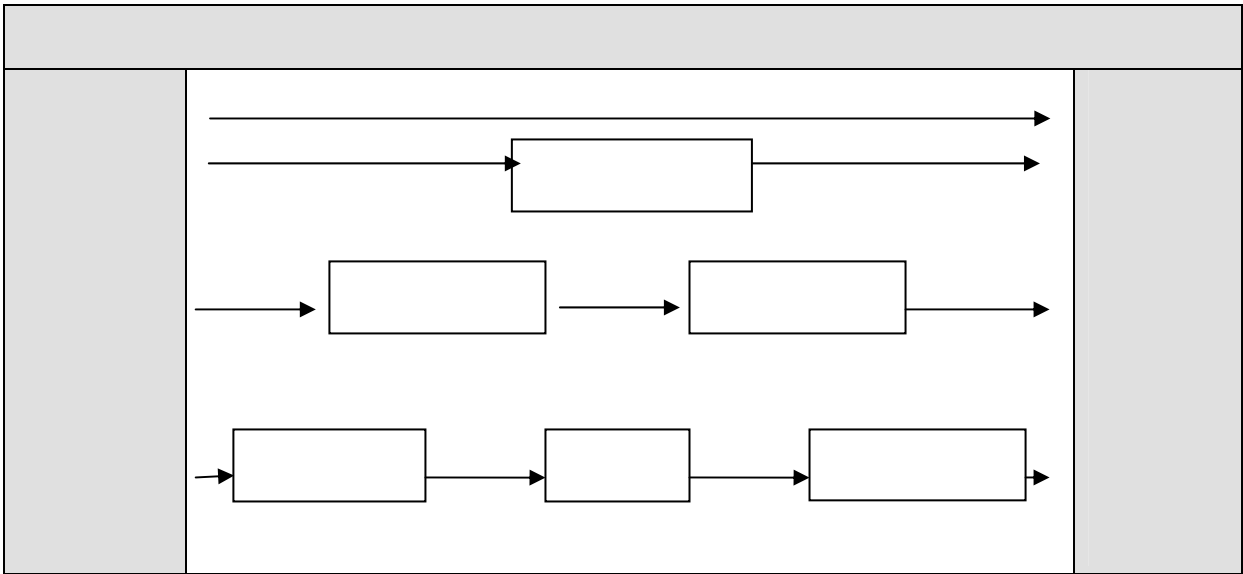

⋮

- 
- 
- 
-

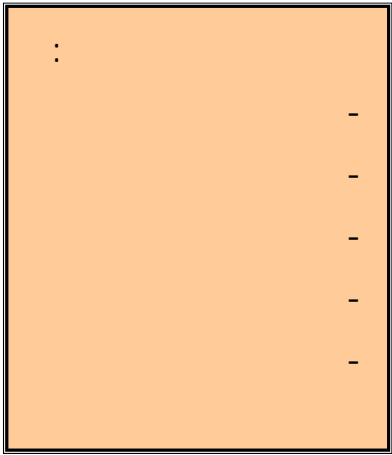

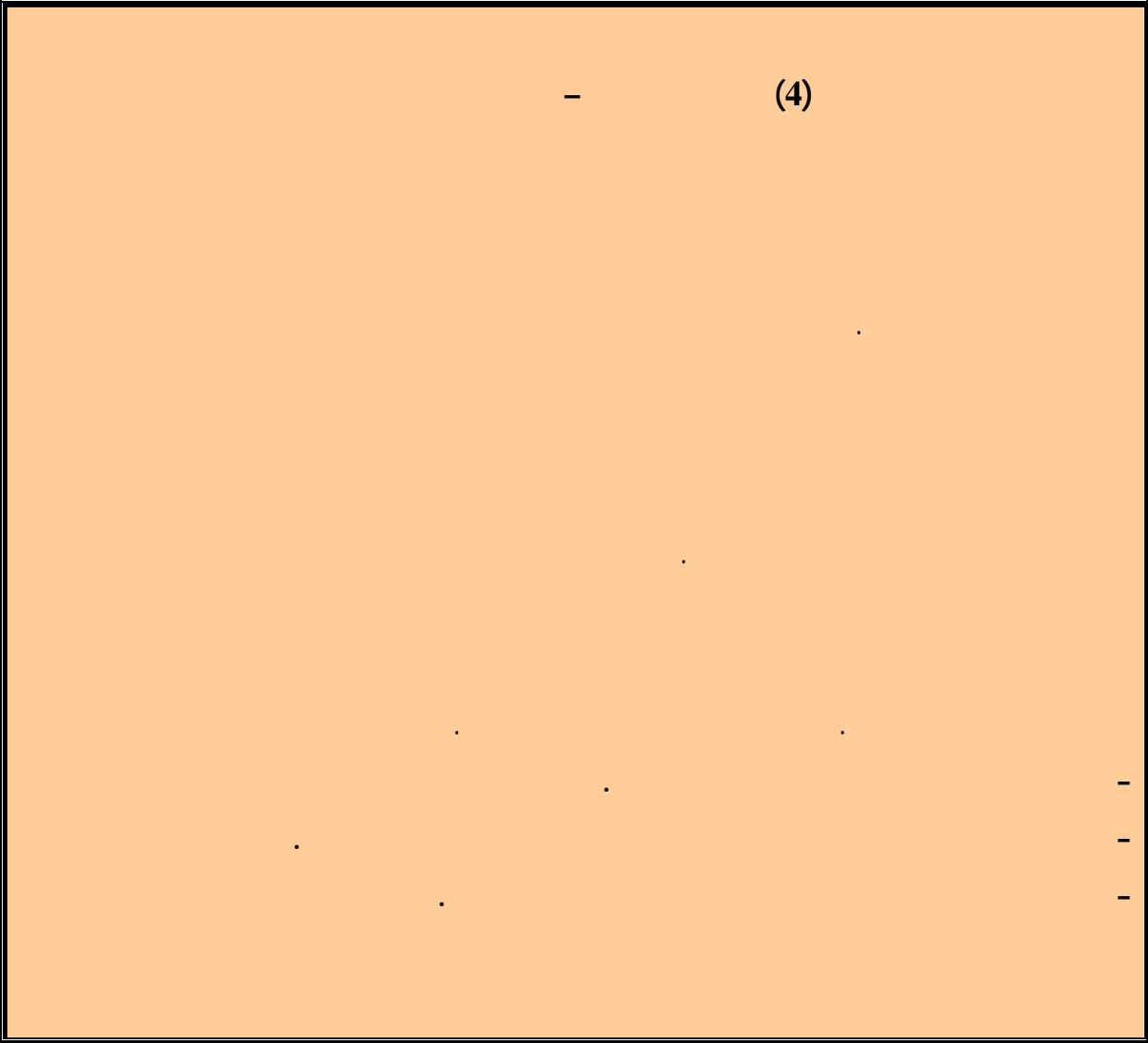

-3

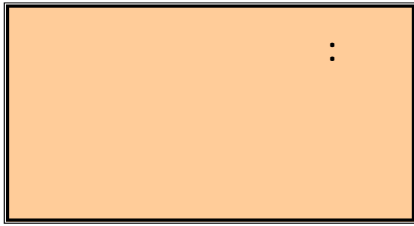

1-3

:

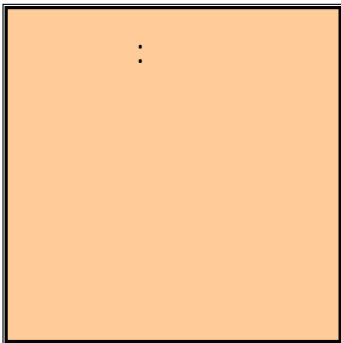

2-3

:



■

■

■

■

■

■

■

■

■

■

.

.

"

"

**3-3**

:

■

■

■

■

■

■

■

■

■

|  | ( ) |
|--|-----|
|  |     |

| 5      | 4 | 3 | 2 | 1 | 0 |        |     |
|--------|---|---|---|---|---|--------|-----|
|        |   |   |   |   |   |        | .1  |
|        |   |   |   |   |   |        | .2  |
|        |   |   |   |   |   |        | .3  |
|        |   |   |   |   |   |        | .4  |
|        |   |   |   |   |   |        | .5  |
|        |   |   |   |   |   |        | .6  |
|        |   |   |   |   |   |        | .7  |
|        |   |   |   |   |   |        | .8  |
|        |   |   |   |   |   |        |     |
| 5      | 4 | 3 | 2 | 1 | 0 |        |     |
|        |   |   |   |   |   |        | .1  |
|        |   |   |   |   |   |        | .2  |
|        |   |   |   |   |   |        | .3  |
|        |   |   |   |   |   |        | .4  |
|        |   |   |   |   |   |        | .5  |
|        |   |   |   |   |   |        | .6  |
|        |   |   |   |   |   |        | .7  |
|        |   |   |   |   |   |        | .8  |
|        |   |   |   |   |   |        | .9  |
|        |   |   |   |   |   |        | .10 |
|        |   |   |   |   |   |        | .11 |
|        |   |   |   |   |   |        |     |
| :      |   |   |   |   |   | :      |     |
| 50 :   |   |   |   |   |   | 35 :   |     |
| 49-40: |   |   |   |   |   | 34-30: |     |
| 39:    |   |   |   |   |   | 29:    |     |